

Introduction to the Mechanical Engineering Discipline through Hands-on Product Development Case Studies

G. Altuger, S. Tumkor, C. Chassapis

Stevens Institute of Technology, Department of Mechanical Engineering, Hoboken, NJ, 07030, USA
GAltuger@stevens.edu, STumkor@stevens.edu, and CChassap@stevens.edu

Abstract - Product development is a set of rules, procedures and practices that are applied to the launch of a new product to the market. It involves all the steps from design to manufacturing including prototyping, fabrication and testing. This makes the product development process a good candidate to introduce the world of Mechanical Engineering to the new students or prospect ones. The Mechanical Engineering Department at Stevens Institute of Technology offers summer outreach programs for high school students that aim to introduce the Mechanical Engineering discipline with hands – on experiences by exposing aspects that go beyond theory and requires creativity and innovativeness such as design, fabrication and manufacturing. During the outreach program students are given a brief overview of what design, prototyping and manufacturing is, followed by free hand sketching and solid modeling (SolidWorks tutorials) The student apply all these to address the needs of a particular product design. The efforts culminates to the manufacturing the prototypes using various rapid prototyping technologies. The product development exercise of the outreach program helps students gain hands – on experience as they enhance their understanding of the Mechanical Engineering discipline. Collected student feedback confirms that the outreach program provides high school students a clear overview of the offerings of the discipline, answers their questions about the Mechanical Engineering curriculum and helps them make an educated engineering discipline choice for college applications.

Keywords – Product development, outreach program, hand-on prototyping

I. INTRODUCTION

Several teaching approaches have been used through the process of introducing Mechanical Engineering discipline to students. Arango et al [1, 2] summarized the five categories of recommended learning style models as: sensing/intuitive, visual/verbal, inductive/deductive, active/reflective, and sequential/global. Aziz and Chassapis [3] highlighted that based on Kolb's learning cycle, information transformed to knowledge by either active experimentation or reflective observation, and engineers are more likely to be active learners. Tumkor and Pochiraju [4] stated that a popular approach to teach undergraduate engineering design is through a structured, problem solving method that students use to tackle open – ended design problems. Product development process not only considers the design aspect but also considers the

manufacturing, and testing aspects. Ulrich and Eppinger [5] listed the characteristics of a successful product development as: product quality, product cost, development time, and development cost and development capability.

The Mechanical Engineering Department at Stevens Institute of Technology initiated to provide an outreach program for high school students. The focus of this program is on design and rapid prototyping applications in a product development process. For the design process both free hand sketching and Computer – Aided Design technologies are used. Bertoline [6] presents how design tools evolved from pencils to CAD. Through the outreach program students will use SolidWorks software as their CAD software. Once the design process is completed, 3 – D models than can be loaded to a rapid prototyping machine to create prototypes. Chua, Leong, and Lim [7] listed the role of a prototype in the product development process as:

1. Experimentation and Learning
2. Testing and Proofing
3. Communication and Interaction
4. Synthesis and Integration
5. Scheduling and Markers

Throughout the outreach program Z-Corporation's 3D Rapid Prototyping machine will be used. Chua, Leong and Kim [7] listed the main advantages of Z-Corp's machine as: high speed, versatile, simple to operate, no wastage of materials and color, making this rapid prototyping application a great candidate for educational purposes. Through out this study, the outreach program details, program outcomes and student feedback will be presented.

II. OUTREACH PROGRAM DESCRIPTION

The outreach program for high school students is built to introduce the Mechanical Engineering discipline. The program aims to not only expose the basics of the Mechanical Engineering to consider it as a career option but also provide students with hands-on engineering experience in developing essential skills and knowledge. The program material is based on following course work: Engineering Experiences (E 101), Engineering Graphics (E 120), and Computer Aided Design and Manufacturing (ME 491). The material and course outline followed also aims to teach students basic academic skills such as: self motivation, goal orientation, problem solving and decision-making. Throughout their participation, the

students undertake free hand sketching, computer aided design with SolidWorks, and rapid prototyping technologies. The course sections are shown in the Fig. 1.

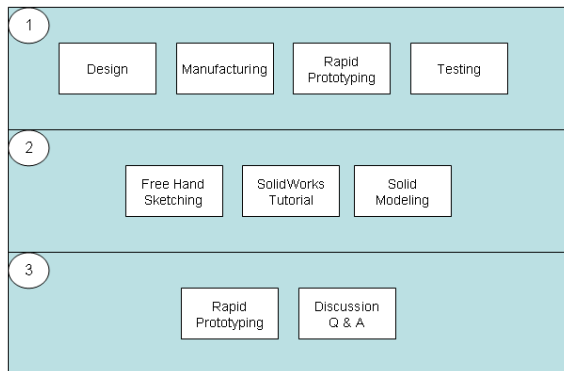

Fig. 1. Outreach program course sections 1, 2 and 3

The Mechanical Engineering Department outreach course consists of three sections. The first section is a series of lectures, during which the instructor covers the basics of Mechanical Engineering such as: Design, Computer Aided Design, Manufacturing, and Computer Aided Manufacturing, Simulations and Analysis, Rapid Prototyping, Fabrication and Testing as well as Career Options for Mechanical Engineers. In the second section, students work on various individual, hands-on projects followed by discussions. The section continues with a self-paced SolidWorks tutorial session, and finalized by individual solid modeling via SolidWorks. The third section is composed of complete hands-on Rapid Prototyping Session. In this session, students load their models to the rapid prototyping machine computer, configure the system based on preferences and produce the final prototype. During the rapid prototyping process, even though the students are encouraged to perform their tasks self sufficiently, they were provided with ample assistance from the instructor and the engineer on a needed by basis. Further detail on lecture sections and sub- sections will be provided with illustrations in this study.

1. Section One: Series of Lectures

Design: In the design section of the lecture series students are introduced to basic design concepts and definitions. Questions such as “What is Design” or “What is Engineering Design” are answered. Design steps from free hand sketching to 2-D Design to 3-D Design and solid modeling as shown in Fig. 2 are discussed. Along with the design phases, various CAD software applications and examples are also covered in this section.

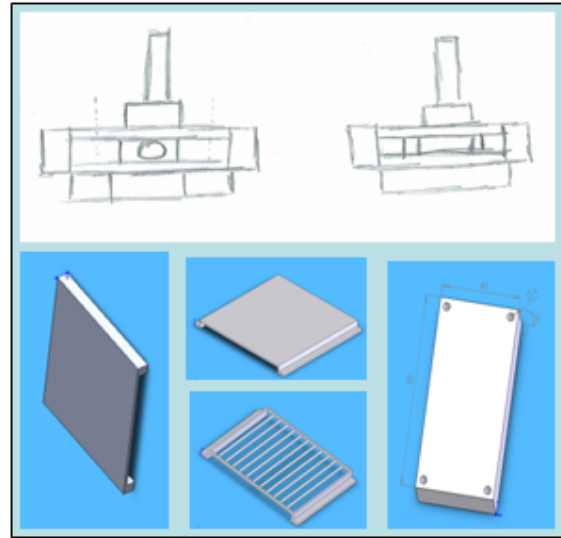

Fig. 2. From Hand Sketch to Solid Models

Manufacturing: The manufacturing section highlights the current state of manufacturing technology and lists several manufacturing applications such as: drilling, welding, plastic injection molding, etc... To emphasize the importance of Computer Aided Manufacturing Software, a plastic injection molding example with a gate selection problem is presented and solved via ProPlastic.

Rapid Prototyping: The role of rapid prototyping in the product development process is explained as well as how prototypes are used as tool for communication, demonstration, test and proof of ideas or concepts in product development process. Different rapid prototyping technologies and techniques such as: Z-Corporation 3 D Printing, Stereo-lithography, Selective Laser Sintering, and Fused Deposition Molding are presented. More emphasize is put on the Z-Corporation 3 Dimensional Printing, by showing students instructional videos of how to set up the 3D printer, how to load solid models (*.stl files) to the computer, and how the machine operates.

The following process descriptions are used for explaining Z-Corporation 3 D Printing Technology:

- a). The printer starts with spreading a layer of powder. The printer applies a plastic based binding solution on to the loose powder to form a hardened layer.
- b). As the printer spread the powder into layers, it applies plastic based binding liquid to solidify the layers. Remaining unused powder stays in the powder form.
- c). The 3 D printer prints the part layer by layer; as the part forms, it gets completely covered with loose powder.
- d). Once the part is fully completed, the build piston is raised; the loose powder above the part is vacuumed providing an easy access to the part. Once the part is removed, the excess powder (the loose powder) on the part can also be vacuumed at a cleaning station.
- e). Once the process is completed, the part can be waxed, sanded, or resined for evaluation

Testing: In the last part of the lecture series, the necessity of testing is explained to the students. Various testing techniques and use of prototypes in the testing phase are covered providing example. Testing process is introduced as the control process of product development with use of prototypes aiming to verify that the end product meets the initial goals and expectations.

2. Section Two: Individual Hands-on Tutorials, Design and Discussions

Free Hand Sketching: In this section, students are asked to sketch a product either of their choice or from a list of products (mechanical toothbrush, cordless drill, hand blender, etc.) provided to them. The importance of free hand sketching in the early design process is emphasized. Hand sketches help them getting started with their 3D solid modeling. Their detailed 3D Solid models visualize the end product. Once the students finish their sketches, they are asked to present and comment on each other's designs. This gives the students opportunities to express their designs and their approach as well as exchanging ideas with other members of the program.

SolidWorks Tutorial: SolidWorks is one of the vastly used CAD software in the Mechanical Engineering department, and all Mechanical Engineering students are introduced to SolidWorks in their freshman year in Engineering Graphics (E120) course. The purpose of the SolidWorks tutorial is to familiarize attendees with the software, by teaching basic commands, functions, drawing and modeling features to design and model at novice level. With the provided tutorial, students learn how to use the following features and commands: plane selection, sketch, line and circle, extrude, extruded cut, copy/paste, mirror, trim, chamfer, fillet, hole, and linear pattern. Students are also introduced to how to measure various dimensions of their designs, and how to select cross-sectional areas and surfaces for editing. Even though the students do the tutorials individually, an instructor is present all times to assist them with their questions.

Solid Modeling: Once the students complete their SolidWorks tutorials, they have the basic design skills and knowledge to perform simple 3D modeling. In this part they are asked to perform individual free style modeling. Some students prefer carrying on with their free hand sketch models to 3D SolidWorks models; where as some of them pick a product to model from the initial products list provided. During the solid modeling part of the class, students are able to use their new SolidWorks skills and commands to creatively design their models.

3. Hands – On Rapid Prototyping

Rapid Prototyping Application: After completion of their individual SolidWorks models, students converted their *.prt files to *.stl files as they were instructed, and headed to the Rapid Prototyping stations. The rapid prototyping

machines the students use are Z-Corporation 3 Dimensional printers. Previously instructed on the rapid prototyping machine, students load print their models on the 3 D printer. They were assisted by the instructor and the machine engineer when needed during this process. Students were asked to remove their prototypes and clean up their area once the printings are completed. Finished prototypes can be seen in Fig. 3.



Fig. 3. Finished Prototypes

Discussion: After the hands on session, the students were encouraged for final discussion and evaluation of their experiences in a classroom environment. During the discussions, students shared their program experience, and their perception of the Mechanical Engineering discipline. They were also asked to give feedback on their overall experience of the outreach program.

III. PROGRAM OUTCOMES

The goal of the outreach program is to introduce students to the Mechanical Engineering discipline utilizing materials collected from basic Mechanical Engineering classes and hands-on projects. The program aims to emphasize on the role of design, modeling, manufacturing and prototyping in mechanical engineering by shifting the focus from math and physics. During the final discussion of the program, students are asked to give feedback on the program based on their experience.

The feedbacks are as follows:

- The outreach program gave me a better understanding of the Mechanical Engineering discipline and helped me focus on the importance of career selection.
- My attitude towards engineering and mechanical engineering in particular changed very positively as a result of the solid modeling and hands-on prototyping experience
- The program was a great exposure to the Mechanical Engineering discipline; especially the rapid prototyping part of the program was a great opportunity.
- To see how a free hand sketch can transform to a 3 Dimensional product and to actually perform that was a

great experience, and definitely makes me consider Mechanical Engineering in my college applications.

- I had no prior knowledge or experience on any engineering majors, and the hands-on study helped me develop basic sense of engineering in general as well as Mechanical Engineering.

The feedbacks suggest that the program met its primary goal of introducing the Mechanical Engineering discipline. In addition to its goal, the program help the students improve on their time management and presentation skills. Overall the program provided a clear overview of the Mechanical Engineering discipline.

IV. CONCLUSION

Product development process is a great candidate to introduce Mechanical Engineering discipline to non-engineers since it involves all steps from design to manufacturing and can be briefed on without having to cover the scientific knowledge it is built upon. Through the outreach program, students learned about the basics of design, development, manufacturing, rapid prototyping, and career opportunities in mechanical engineering. The hands-on project presented during the outreach program enabled students to improve their time management and presentation skills. Collected feedback validates the success of the program in introducing the discipline to prospective Mechanical Engineering students.

REFERENCES

- [1] Arango, F., Altuger, G., Aziz, E.-S., Esche, S. K. & Chassapis, C. (2008). Piloting a game-based virtual learning environment. *Computers in Education Journal*, Vol. 18, No. 4, pp. 82-91.
- [2] Arango, F., Altuger, G., Aziz, E.-S., Esche, S. K. & Chassapis, C. (2008). Piloting a game-based virtual learning environment. *Proceedings of the 2008 ASEE Annual Conference and Exposition*, Pittsburgh, Pennsylvania, USA, June 22 - 25, 2008.
- [3] Aziz, E.- S., Chassapis, C. (2008). Introduction to the ME Curriculum through Product Engineering Case Studies. *Proceeding of the 38th ASEE/IEEE Frontiers in Education Conference*, Saratoga Springs, NY, USA, October 22-25, 2008
- [4] Tumkor, S., Pochiraju, K., (2008). Rapid Prototyping in the Design Methodology. *Proceedings of the 2008 ASEE Annual Conference and Exposition*, Pittsburgh, Pennsylvania, USA, June 22 - 25, 2008.
- [5] Ulrich, K.T., Eppinger, S. D., *Product Design and Development*, 4th Edition, Mc Graw Hill, 2008, USA
- [6] Bertoline, G., *Introduction to Graphics Communications for Engineers*, 3rd Edition, Mc Graw Hill,
- [7] Chua C. K., Leong, K. F., Lim, C. S., *Rapid Prototyping*, 2nd Edition, World Scientific, 2003, USA